

Operator's manual Manual de instrucciones
Instruções para o uso Οδηγίες χρήσης

WS220



Please read the operator's manual carefully and make sure you understand the instructions before using the machine.

Lea detenidamente el manual de instrucciones y asegúrese de entender su contenido antes de utilizar la máquina.

Leia as instruções para o uso com toda a atenção e compreenda o seu conteúdo antes de fazer uso da máquina.

Διαβάστε προσεκτικά τις Οδηγίες χρήσης και κατανοήστε το περιεχόμενό πριν χρησιμοποιήσετε το μηχάνημα.

GB (2-28)

ES (29-54)

PT (55-81)

GR (82-109)

Gna Vc`g`cb`h`Ya UW JbY.

WARNING! The machine can be a dangerous tool if used incorrectly or carelessly, which can cause serious or fatal injury to the operator or others.

Please read the operator's manual carefully and make sure you understand the instructions before using the machine.

Always wear:

- Approved protective helmet
- Approved hearing protection
- Protective goggles or a visor
- Breathing mask

Inspection and/or maintenance should be carried out with the motor switched off and the plug disconnected.

This product is in accordance with applicable EC directives.

9bj]rcba YbH`a U`_]b["Symbols on the product or its packaging indicate that this product cannot be handled as domestic waste. It must instead be submitted to an appropriate recycling station for the recovery of electrical and electronic equipment.

By ensuring that this product is taken care of correctly, you can help to counteract the potential negative impact on the environment and people that can otherwise result through the incorrect waste management of this product.

For more detailed information about recycling this product, contact your municipality, your domestic waste service or the shop from where you purchased the product.

CH`Yf`gna Vc`g`#KYWU`g`cb`h`Ya UW JbYfYZf`hc`gd`YVU` WfH`ZVU`jcb`f`Yei`Jf`Ya`Yb`rg`Z`f`WfH`U`j`b`a`Uf`_Ytg`



9I d`UbU`jcb`c`Zk Uf`b]b[``Yj`Y`g`

The warnings are graded in three levels.

K 5 FB-B; °

K 5 FB-B; ° I gYX`JZH`YfY`]g`Uf]g`_cZ`gYf]ci`g`]b`f`f`mrcf`XYU`h`Z`f`h`Y`cdYfU`c`f`cf`XU`a`U`Y`h`h`Y`gi`f`fci`bX]b]`g`]ZH`Y`]b`g`f`i`W]c`b`g`]b`h`Ya`U`bi`U`U`f`Y`b`c`h`i`Z`_`c`k`YX`"

=A DCF H5 BH°

=A DCF H5 BH° I gYX`JZH`YfY`]g`Uf]g`_cZ`]b`f`f`mrc`h`Y`cdYfU`c`f`cf`XU`a`U`Y`h`h`Y`gi`f`fci`bX]b]`g`]ZH`Y`]b`g`f`i`W]c`b`g`]b`h`Y`a`U`bi`U`U`f`Y`b`c`h`i`Z`_`c`k`YX`"

7 5 I H-CB °

CAUTION! Used if there is a risk of damage to materials or the machine if the instructions in the manual are not followed.

7 cbH9bhg

79 MHC 6 MA 6 C @G

Symbols on the machine:	2
Explanation of warning levels	2

7 CBH9 BHG

Contents	3
----------------	---

DF9 G9 BH5 HCB

Dear Customer,	4
Design and features	4
WS 220	5

K < 5H-GK < 5H3

What is what on the wall saw?	6
-------------------------------------	---

A57 < -B9 SG G5 : 9HM9 EI -DA9 BH

General	7
---------------	---

CD9F5HB;

Protective equipment	8
General safety precautions	8
Work safety	9
Before sawing	10
Basic working techniques	11

5GG9A6 @B; 5B8 58 >I GHA9 BHG

Assemble the wall mountings	13
Fit the wall mounting as set out below:	13
Mirrored wall brackets	13
Connection of rails	14
Assemble the rail	14
Saw unit	15
Mount the saw onto the rail	15
Fit the blade	16
Fit the blade guard	17
Connect the power pack	19

G5 FHB; 5B8 GHCDD-B;

Before starting	20
Remote control	20
Stopping	22
Dismantling and cleaning	22

A5 -BH9 B5 B7 9

Service	23
Maintenance	23
Daily maintenance	23
Adjusting the guide wheels	23
Adjusting the blade guard guide	24

H97 < B-7 5 @85H5

WS 220	25
EC Declaration of Conformity	27
UK Declaration of Conformity	28

8 YU'7 i glca Yř

Thank you for choosing a Husqvarna product!

It is our wish that you will be satisfied with your product and that it will be your companion for a long time. A purchase of one of our products gives you access to professional help with repairs and services. If the retailer who sells your machine is not one of our authorised dealers, ask him for the address of your nearest service workshop.

This operator's manual is a valuable document. Make sure it is always at hand at the work place. By following its content (using, service, maintenance etc.) the life span and the second-hand value of the machine can be extended. If you will sell this machine, make sure that the buyer will get the operator's manual.

AcfYH Ub' \$mYUfg cZjbbc j Uřcb

Husqvarna AB is a Swedish company based on a tradition that dates back to 1689, when the Swedish King Charles XI ordered the construction of a factory for production of muskets. At that time, the foundation was already laid for the engineering skills behind the development of some of the world's leading products in areas such as hunting weapons, bicycles, motorcycles, domestic appliances, sewing machines and outdoor products.

Husqvarna is the global leader in outdoor power products for forestry, park maintenance and lawn and garden care, as well as cutting equipment and diamond tools for the construction and stone industries.

Ck bYf'fYgdcbgjVj]m

It is the owner's/employer's responsibility that the operator has sufficient knowledge about how to use the machine safely. Supervisors and operators must have read and understood the Operator's Manual. They must be aware of:

- The machine's safety instructions.
- The machine's range of applications and limitations.
- How the machine is to be used and maintained.

National legislation could regulate the use of this machine. Find out what legislation is applicable in the place where you work before you start using the machine.

H Y a Ubi ZWfi fYfđ'fYgYf j Uřcb

All information and all data in the Operator's Manual were applicable at the time the Operator's Manual was sent to print.

Subsequent to publishing this manual Husqvarna may issue additional information for safe operation of this product. It is the owner's obligation to keep up with the safest methods of operation.

Husqvarna AB has a policy of continuous product development and therefore reserves the right to modify the design and appearance of products without prior notice.

8 Yg]] b'UbX'ZUfi fYg

The WS 220 is a rail mounted wall saw which is used with segmented diamond blades to cut hard materials such as reinforced concrete, stone and brick. During development of the WS 220, great focus has been placed on product weight and user-friendliness, in order to improve and streamline the operator's work environment. With its low weight, compact design and powerful high-frequency engine, the WS 220 is a wall saw which can handle most jobs. Designed for 600-900 mm blades, this saw is able to cut through wall thicknesses of up to 390 mm. The sawing system is stored on a compact transport trolley, which facilitates transportation to and from the workplace.

The Wall Saw is designed to cut hard materials like concrete or reinforcement and should not be used for any purpose not described in this manual. Safe operation of this product requires the operator to read this manual carefully. Ask your dealer or Husqvarna should you need more information.

Some of the unique features of your product are described below.

DF 9 G9 BH5 HCB

K G &&\$

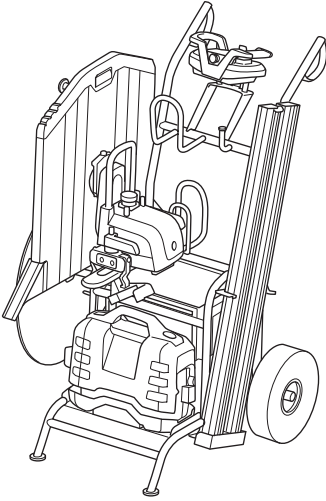

- Remote control of the machine by radio communication for optimal mobility and supervision.
- Short distance between blade and track, for a straighter cut.
- Slip clutch for all movable components.
- The blade's direction of rotation can be controlled with the remote control which allows one to choose the direction of the water spray.
- Equipped with automatic blade brake that stops the blade within a few seconds.
- All the equipment can be transported easily with the help of the accompanying compact transport trolley.

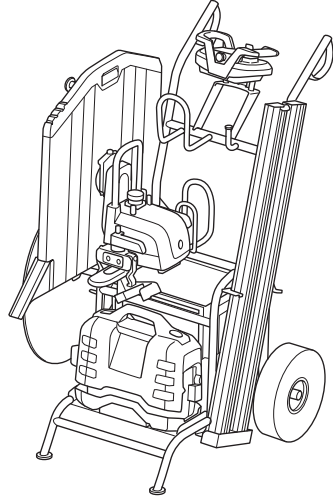

5 'Vēa d'YH'gUk]b['gnghYa 'Zf'Yl YW]b['h Y'k cf...']g'
 g'hc fYX'cb'h YUWVēa dUbn]b['Vēa dUWifUbgdcf'h
 ffc''YmUbX'Vēa d]gYg'h Y'Z''ck]b[.

- 1 Compact transport trolley
- 2 Saw unit
- 3 Rail unit, 2x 1084 mm
- 4 Blade guard, 600 mm
- 5 Power unit PP 220
- 6 Power cable
- 7 Water hose, 8 m
- 8 Accessory box, containing 2 wall mounts, blade guard guide, and other accessories
- 9 Storage box, remote control

K <5H'G'K <5H3

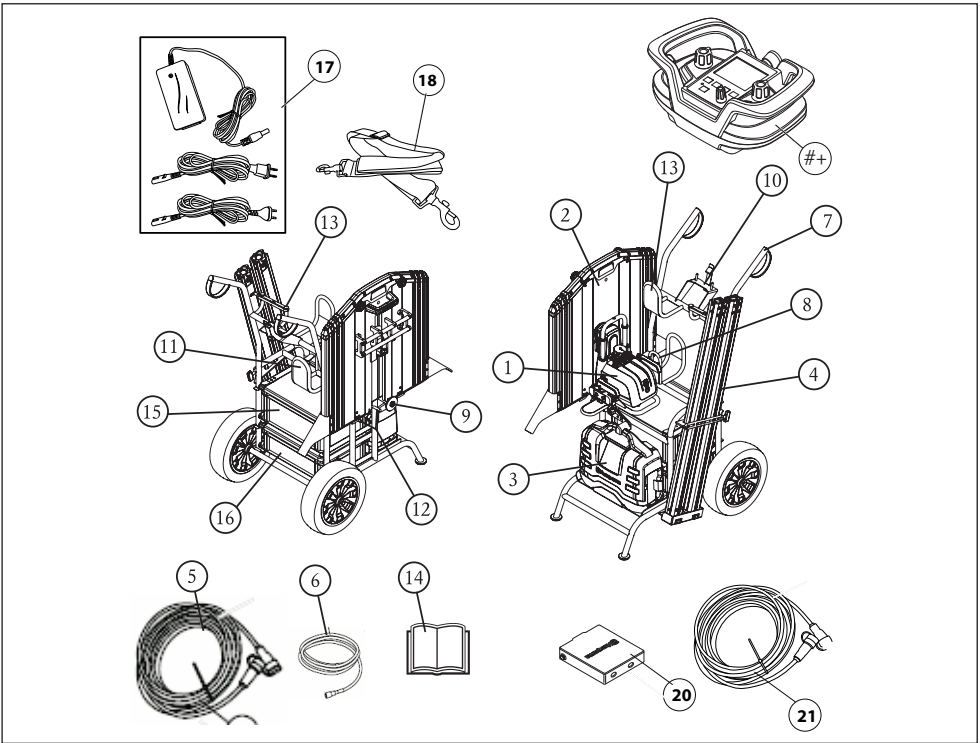

K \ Uh]g'k\ Uhcb'h Yk U''gUk 3

- | | |
|----------------------------|------------------------------------|
| 1 Saw unit | 12 Holder, residual current device |
| 2 Blade guards | 13 Holder, hand cutter |
| 3 Power pack | 14 Operator's manual |
| 4 Track | 15 Storage box, remote control |
| 5 Power cable | 16 Storage box, accessories |
| 6 Water hose | 17 Battery |
| 7 Conveyor cart | 18 Adjustable carry strap |
| 8 Lifting eye | 19 Remote control |
| 9 Blade mount | 20 Battery charger |
| 10 Remote control holder | 21 CAN cable |
| 11 Hose and cable fittings | |

A57 < -B9§G'G5 : 9HM9EI -DA9BH

; YbYfU

This section describes the machine's safety equipment, its purpose, and how checks and maintenance should be carried out to ensure that it operates correctly. See the "What is what?" section to locate where this equipment is positioned on your machine.



K 5 FB-B; "BY' Yf i gY'Ua UW]bY'h Uh Ug'
ZLi 'hmgUZ/miYei]da Ybfi'GUZ/mi
Yei]da Ybha i ghVY']bgdYW'X'UbX'
a U]bHJ]bYX''GY']bgfii W]cbg'i bXYf 'h Y'
\ YUX]b['7\ YW]b[ža U]bHJ]b]b['UbX'
gYf j]W]b['h Y'a UW]bY'g gUZ/mi
Yei]da YbH'-Znci f'a UW]bY'XcYg'bch
dUgg'U''h Y'W YW gZHU_Y']hnc' U'gYf j]W'
k cf_g' cd Z'f'YdU]f''

6`UXY[i UFXg

The blade guard must always be used when sawing. Make sure the blade guard is in working order and that the outer sections can be locked in place. Also check that the blade guard guide is adjusted correctly and that the locking mechanism in the blade guard guide for the saw is in working order (see the adjusting the blade guard guide section). Check that the blade is not in contact with the guard but is centred in the blade guard.

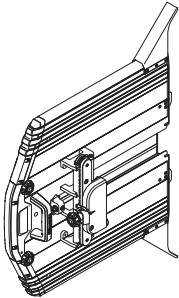

6`UXY[i UFX`cW

Make sure the screw for the blade guard guide is screwed on when the blade guard is fitted.

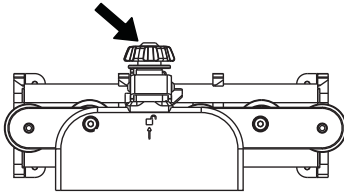

9bX'glt'd'cb`h YfU]

Make sure that end stops are mounted on the ends of the rails so that the saw does not come off the rails.

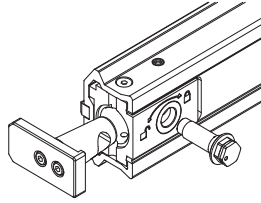

Dck Yf`dUW

Make sure to check the safety equipment on the supplied power unit. See the power unit manual.

K U`a ci b]b]

Place the wall mounts approximately 1/4 of the way in on the rail. A minimum of two wall mounts must be used while sawing, if more rails are spliced together, one wall mount is required for each rail section.



HUW

Make sure the rail joints are assembled correctly and that the eccentric bolt is tight.

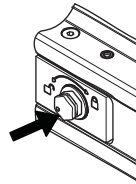
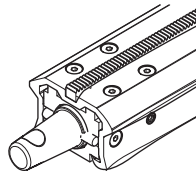

FYa ch'W`b]fc`

The Stop button shuts down the remote control and stops the saw unit.

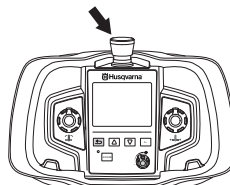

DfchWVj YYei Jda Ybh

; YbYfU

Do not use the machine unless you are able to call for help in the event of an accident.

DYfgcbU`dfchWVj YYei Jda Ybh

You must use approved personal protective equipment whenever you use the machine. Personal protective equipment cannot eliminate the risk of injury but it will reduce the degree of injury if an accident does happen. Ask your dealer for help in choosing the right equipment.

; YbYfU`gUZymdfYU hcbg



K5FB-B; "FYUX" `gUZymik Ufb]b[g`UbX` U`]bgfii Wjcbg": Uj i fYtc`Z`ck`h`Y` k`Ufb]b[g`UbX`]bgfii Wjcbg`a` Urif Ygi`h]b` Y`YWF]Wgl`c`W`Zzf`Y`UbX`#f`gYf]ci`g`]b`f`fml`

This section describes basic safety directions for using the machine. This information is never a substitute for professional skills and experience. If you get into a situation where you feel unsafe, stop and seek expert advice. Contact your dealer, service agent or an experienced user. Do not attempt any task that you feel unsure of!

- Please read the operator's manual carefully and make sure you understand the instructions before using the machine.
- This machine is only intended for use together with the Husqvarna PP 220 power units. Read through the manual supplied with the power pack before starting to use the machine. All other use is forbidden.
- The machine can cause serious personal injury. Read the safety instructions carefully. Learn how to use the machine.
- This machine is designed for and intended for sawing concrete, brick and different stone materials. All other use is improper.
- Keep in mind that the operator is responsible for accidents or hazards occurring to other people or their property.
- All operators shall be trained in the use of the machine. The owner is responsible for ensuring that the operators receive training.
- The machine must be kept clean. Signs and stickers must be fully legible.



K5FB-B; "H`Y`i`gY`cZ`d`f`c`X`i`W`g`i`W`U`g` W`H`Y`f`g`Z`]`f`]b`X`Y`f`g`Z`X`f`]"`g`Z`H`U`ng`U`b`X`c`f`Z`f`a` ` a`U`H`f`]`U``V`U`b`[`Y`b`Y`U`H`X`i`g`h`U`b`X`j`U`d`c`i`f`g` k` \ `J`W` `a` U`ri`V`e`b`H`U`b` \ `U`n`U`f`X`c`i`g`W`Y`a`]`W`U`g`" ` 7` \ `Y`W` `H` `Y`b`U`h`f`Y`c`Z`H`Y`a`U`H`f`]`U``m`c`i` `]`b`h`b`X`h`c`d`f`c`W`g`g`U`b`X`i`g`Y`U`b`U`d`d`c`f`d`]`U`H`Y` V`f`Y`U`H`]`b`[` `a`U`g`_`

@`b`[`]`H`f`a` `Y`i`d`c`g`i`f`Y`t`c`b`c`]`g`Y`V`U`b`f`Y`g`i` `h`]`b`d`Y`f`a`U`b`Y`b`h`Y`U`f`]`b`[`]`a`d`U`f`a`Y`b`h`G`c` `U`k`U`ng`i`g`Y`U`d`d`f`c`j`Y`X` \ `Y`U`f`]`b`[`d`f`c`H`W`V`j`c`b`" ` @`g`h`Y`b`c`i`h`Z`f`k`U`f`b`]`b`[`]`g`]`b`U`g`c`f`g`l`c`i`h`g` k` \ `Y`b` `m`c`i` `U`r`Y`k`Y`U`f`]`b`[` \ `Y`U`f`]`b`[` `d`f`c`H`W`V`j`c`b`" `5` `k`U`ng`f`Y`a`c`j`Y`n`c`i`f` \ `Y`U`f`]`b`[` `d`f`c`H`W`V`j`c`b` `U`g`g`c`b`U`g`h`Y`Y`b`[`]`b`Y`g`f`c`d`g`"

H`Y`f`Y`]`g`U`k`U`ng`U`f`]`g`_`c`Z`W`i`g`l` `]`b`f`]`Y`g` k` \ `Y`b`k`c`f`_`]`b`[`]`k`]`h` `d`f`c`X`i`W`g`V`e`b`H`U`b`]`b`[` `a`c`j`]`b`[`d`U`f`]`g`" `K`Y`U`f`d`f`c`H`W`V`j`Y`[`]`c`j`Y`g`t` `U`j`c`]`X`V`c`X`m`]`b`f`]`Y`g`"

Always wear:

- Approved protective helmet
- Hearing protection
- Protective goggles or a visor
- Breathing mask
- Heavy-duty, firm grip gloves.
- Tight-fitting, heavy-duty and comfortable clothing that permits full freedom of movement.
- Boots with steel toe-caps and non-slip sole.

Be careful as clothing, long hair, and jewellery can get caught in moving parts. Wear protective hair covering to contain long hair.

CH`Yf`dfchWVj YYei Jda Ybh



K5FB-B; "H`Y`a`U`W`]`b`Y`V`U`b`V`Y`U` X`U`b`[`Y`f`c`i`g`t`c`c`]"`Z`i`g`Y`X`]`b`V`e`f`f`Y`W`m`i`c`f` `V`U`f`Y`g`g`n`z`k` \ `]`W` `V`U`b`V`U`i`g`Y`g`Y`f`]`c`i`g`c`f` `Z`H`U` `]`b`f`f`m`i`c` `h`Y`c`d`Y`f`U`c`f`c`f`c`h`Y`f`g`"

B`Y`j`Y`f`U`c`k`W`]`X`f`Y`b`c`f`c`h`Y`f`d`Y`f`g`c`b`g` `b`c`h`f`U`b`Y`X`]`b`h`Y`i`g`Y`c`Z`H`Y`a`U`W`]`b`Y`t`c` `i`g`Y`c`f`g`Y`f`]`W`]`h`B`Y`j`Y`f`U`c`k`U`b`n`c`b`Y`Y`g`Y` `t`c`i`g`Y`h`Y`a`U`W`]`b`Y`k`]`h`c`i`h`Z`f`g`h`Y`b`g`i`f`]`b`[` `h`U`h`i`Y`m`l`U`j`Y`f`Y`U`X`U`b`X`i`b`X`Y`g`t`c`c`X`h`Y` `V`e`b`h`b`Y`b`g`c`Z`H`Y`c`d`Y`f`U`c`f`]`g`a`U`b`i`U`"

B`Y`j`Y`f`i`g`Y`h`Y`a`U`W`]`b`Y`j`Z`n`c`i` `U`f`Y`h`f`Y`X`Z`]`Z` `m`c`i` \ `U`j`Y`X`f`i`b`_`U`V`e` \ `c`z`c`f`]`Z`n`c`i` `U`f`Y` `H`U` `]`b`[` `a`Y`X`]`W`U`h`c`b`h`U`h`e`i` `X`U`Z`Z`V`W`m`c`i`f` `j` `]`g`]`c`b`z`n`c`i`f` `f` `X`]`Y`a`Y`b`h`c`f`m`c`i`f` `V`e`!` `c`f`X`]`b`U`h`c`b`"



K5FB-B; "GdUf`_`g`a`U`ri`U`d`d`Y`U`f`U`b`X`g`U`f`h`i` U`Z`f`Y`k` \ `Y`b` `m`c`i` `k`c`f`_`k`]`h` `h`Y`a`U`W`]`b`Y`" ` 5` `k`U`ng`_`Y`d`Z`f`Y`Z`[` \ `]`b`[` `Y`e`i` `]`d`a` `Y`b`h` \ `U`b`X`r`f`

- Fire fighting equipment
- Always have a first aid kit nearby.

CD9F5H-B;



K5FB-B; "1 bUi h cf]nYX'a cXjZVUjcbg' UbX#f UWWggcf]Yg'a Um'YUX'fc'gYf]ci g']b4 fmicf'XYUA' fc'h Y'i gYf'cf'c'h Yfg"

8c' bchia cXjZmih]g'dfcXi Wfcf'i gY'h]Z]h UddYUfg'fc' Uj Y'VYYb'a cXjZYX'Vnic'h Yfg"

BYj Yf'i gY'U'a UW]bYZVUHf'fmicf' VUHf'fmi W Uf] Yf'h Uh]g'Zi 'mf7 Uf'fmic' h'h Y' W YW'gza Uj]bh'bUbW'UbX'gYf]]W']bgf'i W]cbg'XYgW]VYX']b'h]g'a Ubi U" Gca Y'a Uj]bh'bUbW'UbX'gYf]]W' a YUgi fYg'a i ghVY'VUff]YX'ci hVmfUj]bYX' UbX'ei U]Z]YX'gdYVU]gfg" GYY']bgf'i W]cbg'i bXYf'h Y\ YUX]b] ' A Uj]bh'bUbW'Cb'mi gY'cf]]]bU'gdUfY' dUf]g"

K cf_`gUZf'm

Do not use the machine without first reading and understanding the contents of this Operator's Manual.

K cf_`UFYUgUZf'm

- Always check the back of the wall where the blade comes out when cutting through. Secure, cordon off and make sure that no people can be injured or materials damaged.
- Always check and mark out where gas pipes are routed. Cutting close to gas pipes always entails danger. Make sure that sparks are not caused when cutting in view of the risk of explosion. Remain concentrated and focused on the task. Carelessness can result in serious personal injury or death.
- Make sure that no pipes or electrical cables are routed in the working area or in the material to be cut.
- Make sure that electrical cables within the working area are not live.
- Make sure that no people or animals come closer than 4 m (15 ft) when the machine is running.
- Do not use the machine in bad weather, such as dense fog, rain, strong wind, intense cold, etc. Working in bad weather is tiring and can lead to dangerous conditions, e.g. slippery surfaces.
- Ensure that the working area is sufficiently illuminated to create a safe working environment.
- Always ensure you have a safe and stable working position.

9`YWF]JU`gUZf'm



K5FB-B; "H YfY]g'Uk Ung'Uf]g_`cZ gl'cW'g'Zca 'Y'YWF]JU`midck YfYX' a UW]bYg'5j c]X'i bZj ci fU'Y'k YUA Y'f' V#bX]j]cbg'UbX'VcXmiV#bHUmik]h ']j] \]b]b] ' V#bXi Wcfcg'UbX'a YfU'c'v'YWFg' 5'k Ung'Z'`ck'h Y']bgf'i W]cbg']b'h Y' CdYfUcfcg'a Ubi U'fc'Uj c]X'XUa U] Y"

- Never carry the machine by holding the cable and never pull the plug by pulling the cable.
- Keep all cables away of water, oil and sharp edges. Make sure the cable is not pinched in doors, fences or the like. It can cause the object to become live.
- Check that the cables are intact and in good condition. Use cable intended for outdoor use.
- Never use the machine if any cable is damaged, but hand it in to an authorized service workshop for repair.
- The machine should be connected to an earthed outlet socket.
- Check that the mains voltage corresponds with that stated on the rating plate on the machine.
- 5j c]X'VcXmiV#bHUmik]h 'YUH YX'cf'] fci bXYX' gi fZUWgZgi W' `Ug' d]dYgZf'U]UcfcgZ'Ub] Yg'UbX' fYZ]] YfUcfcg" There is an increased risk of electric shock if your body is earthed or grounded.

DYfcgbU`gUZf'm

- Never leave the machine unsupervised with the motor running.
- Never saw in such a way that you cannot easily reach the emergency stop on the remote control or on the power pack. See power pack manual.
- Make sure that there is always another person close at hand when you use the machines, so that you can call for help if an accident should occur.
- People that need to be in close proximity of the machine must wear the required protective gear, including hearing protection, as the sound level when cutting exceeds 85 dB(A).
- Observe care when lifting. You are handling heavy parts, which imply the risk of pinch injuries or other injuries.
- People and animals can distract you causing you to lose control of the machine. For this reason, always remain concentrated and focused on the task.
- Be careful as clothing, long hair, and jewellery can get caught in moving parts.

I gY`UbX`WfY

- Check that the blade guard is not damaged and that it has been fitted correctly.
- Never use blades other than original blades designed for the machine. Check with your Husqvarna dealer to see which blades are best suited for your usage.
- Never use a damaged or worn blade.
- Never mount or dismount the blade or blade guard without first pulling out the power cable running to the saw unit.
- Never pull out the power cable without first switching off the power pack and waiting for the engine to come to a complete halt.
- Never cut without using the blade guard.
- Check that the blade is not in contact with anything when the machine is started.
- Remain at a distance from the blade when the engine is running.
- Water cooling must always be used. This cools the blades and increases their life and prevents dust build-up.
- Check that all couplings, connections and cables are intact and free from dirt.
- Clearly mark out all cuts to be made before you start sawing, plan these so they can be carried out without danger to persons or the machine.
- Firmly secure or anchor concrete blocks before cutting. The heavy weight of cut material can cause both extensive damage to the machine and serious personal injury if it cannot be moved under controlled conditions.
- Do not saw where there is risk of the block falling onto the blade. A block falling onto a rotating blade can cause damage to the machine as well as personal injury. Use wedges or the like to prevent the block falling when sawing.
- **8 c`bchz`fW`H Y`tc`~`l gY`H Y`WffY`Whtcc`~`zf`nci` f` Udd`~`WU`jcb`**"The correct tool will do the job better and safer at the rate for which it was designed.

HfUbgdcfhUbX`grcfU`Y

- The entire system is supplied on a compact and efficient transport trolley. The transport trolley is designed so that all parts may be removed individually and mounted on the trolley. If it is possible to drive the transport trolley all the way to the workplace, the power unit may be left on the trolley for protection.
- Always switch of the power pack and pull out the electric cable before moving the equipment.
- Dismount the blade and blade guard before transport and storage.
- Store the equipment in a lockable area so that it is out of reach of children and unauthorized persons.
- If there is a risk of freezing, the machine must be drained of any remaining water coolant.
- The transport trolley's handles may be used as runners when lifting it on to truck beds etc., by resting the handles on the bed and then pushing the trolley into it.

6 YZ`fY`gUk`]b[

Get in touch with the site manager to run through the work involved and setting out of the sawing work. Check whether overcutting corners is allowed.

Make sure there are no gas, electric or pipelines within the saw area.

If there is any risk of this, the area must always be detected for each cut in order to ensure no lines are damaged.

Also check with the site manager that there is no work being carried out adjacent to the area to be cut. Secure and cordon off the saw area with a safety distance of at least 4 m and make sure people and materials do not get damaged when sawing.

Make sure the cut out block can easily be taken care of; split it into smaller sections so it is easier to take away.

Check the locations of suitable electric and water supplies before starting work. Install suitable work lighting if necessary.

Make sure the working area is clean and well organized so that the work can be carried out in a safe manner and that flushing water can be taken care of.

6`UXYg

If you change blades to cut deeper in the same cut, make sure the thickness of the blade matches the width of the groove.

6 UgjWk cf _]b['hW b]ei Yg

The movement of the wall saw is controlled by the remote control.

- The blade's rotational direction may be selected by the operator, which means that the water spray may be directed as desired regardless of which way the saw is turned on the rail. Make sure to use the right amount of cooler water for the system and the blade. The cooler water for the blade cools the segments and binds the dust generated through sawing. The water flow may be adjusted using the water regulation spigot.
- Always begin by cutting a guide cut to a depth of 2-4 cm (0,8"-1,6"). This should be cut with a lower feed speed than the maximum possible in order to guarantee a straight cut.

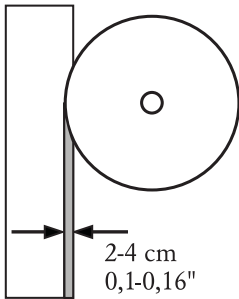

- Subsequent cuts may be made deeper, approximately 4-7 cm (1,6"-2,8"). The depth must be decided on from case to case depending on factors such as the hardness of the concrete, the amount and placement of reinforcement, etc.
- When making these cuts, the longitudinal feed speed should be set to maximum for optimal sawing performance. The feed speed will automatically be regulated by a processor that continually adjusts the speed in order to retain optimal sawing effect.

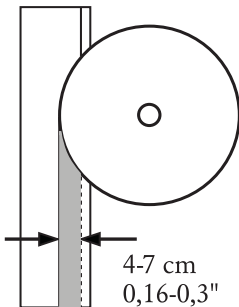

- If the machine is run on single phase operation, the available output is reduced and the cutting depth must be reduced compared to three phase operation. A rule of thumb might be to reduce the cutting depth by half.

- It may often be more time efficient to make shallower cuts in several runs than to attempt a deeper cut. Shallow cuts create less cutting surface and thus put higher pressure on the blade segments, which helps to keep the blade sharp. When cutting rebar lengthwise, it is important to cut the rebar according to the illustration in order to keep the blade sharp. In all other respects the cut should be as shallow as possible. It is also possible to begin cutting from the other end of the cut since it is not certain that the rebar follows the cut the whole way.

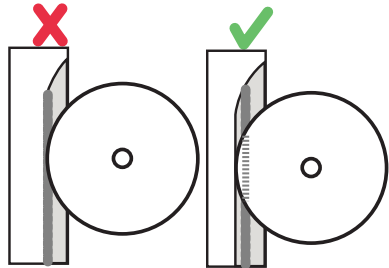

- In cases where the wall is thinner than the maximum depth of the blade, it is advantageous to feed the blade as deep as possible once it has passed through the wall. In this way, the cutting surface is reduced and pressure on the blade's segments is increased. It is also advantageous to work this way in cases when over cutting is not allowed, since the 'wedge' remaining after sewing becomes smaller.

a = Over cut distance

b = Cutting surface

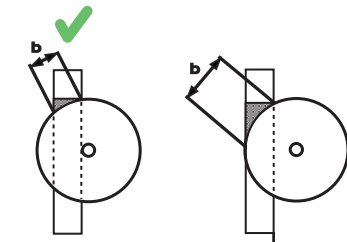
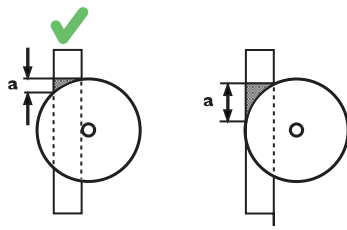

- The blade guard should always be mounted on the saw when in operation. If the blade guard catches the ceiling, for example during over cutting of a doorway, one of the blade guard's gables may be temporarily disassembled.

CD9F5HB;

- When over cutting is not allowed, one may use a hand cutter after a completed wall cutting, and from the rear of the concrete block cut out the leftover 'wedge'. The hand cutters K 6500 and K 6500 RING may be connected directly to the lower outlet on PP 220. The transport trolley also has a designated place for a hand cutter.
- Following a completed cutting, the blade is fully fed out of the sawing groove, after which blade rotation and water flow are shut down. Note! Do not allow the blade to rotate without pressure in the sawing groove for an extended period, since this will quickly blunt it.

7 i H]b['cZV'cW_g

- Before sawing, an assessment must be made of the size of the blocks that may be managed with regard to safety, lifting capacity, and removal. When cutting a doorway for example, it may be convenient to divide it into 4 blocks.
- The rails are symmetrical, which means that it is possible to cut on both sides of the rail without moving it or the wall mounts. This may sometimes be utilized when dividing a larger block into smaller sections.
- The wall mounts are anchored in the wall with expander bolts. The holes for these should be placed approximately 150 mm (5.9 inches) from the cutting groove. In the corners, the same hole may be used for both vertical and horizontal cuts (see illustration). The wall mounts may not be mounted on the part that is to be cut away.

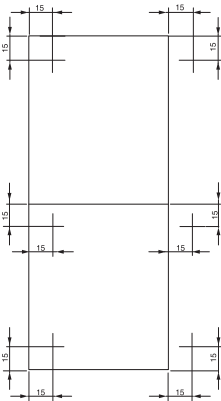

- The holes are drilled for the M10 expander bolts according to the bolt manufacturer's recommendations.
- When cutting a simple rectangular block in a wall, the lower horizontal cut is made first. Following this, the upper horizontal cut is made. Now the two vertical cuts are made. Note! If the lower horizontal cut was done last, the cut out block would fall onto the blade and trap it.

- The illustration below shows the suitable work procedure when sawing with a division into 3 sections.

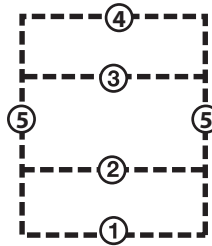

- Hammer in wedges after each cut, two on the saw side and one on the back in order to secure the block all the time.
- When the last cut is made, the rail must be mounted on a stable wall (not on the block that is been cut out). Use the included plastic wedges.
- Make sure that the block being cut out is secured and anchored before cutting begins. The cut out blocks are very heavy and may cause damage to both persons and machines if they are not handled correctly.

5 ggYa VYH Yk U`a ci bh]b[g

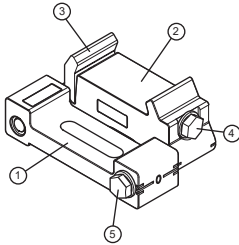

- 1 The half of the wall bracket closest to the wall has grooves for expander bolts as well as a spirit level for horizontal mounting of the bracket.
- 2 The half of the wall bracket that holds the rail has a spirit level for vertical mounting.
- 3 Spring weighted clamping washer. The clamping washer locks the rail to the wall bracket, which enables the rail to be snapped shut in the wall bracket which facilitates mounting.
- 4 Locking screw for tightening the clamping washer.
- 5 Locking screw for angle adjustment. Normally, the two halves should be placed in neutral position which places the blade in a 90° angle to the concrete surface to be cut. The position may however be adjusted for example when cutting an uneven concrete surface.

:]h]h Yk U`a ci bh]b[`Ug`gYici h VYck .

The wall brackets can be placed using the camp and washer on either side of the rail.

Mark the cutting line and mark the holes for the expander bolts approximately 150 mm (5.9 inches) from the cutting line.

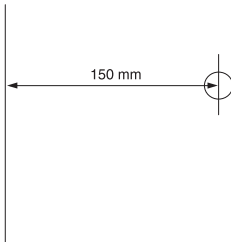

The wall brackets should be placed approximately 1/2 a rail length apart, and the distance between a wall bracket and the end of the rail should be approximately 1/4 of a rail length.

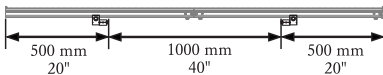

- Drill the holes for the expander bolts according to the manufacturer's instructions. Make sure to use mounting elements adjusted to the material being cut. The sawing equipment is accompanied by a package containing an M10x40 expander anchor for which the hole should be drilled with a 12 mm drill. Follow the instructions on the expander bolt packaging.
- Hang the two wall brackets loosely in the expander bolts, the equipment is accompanied by M10x35 bolts and a Ø10,5x22 washer. Ensure that the bolt's head does not rise above the rail plane.

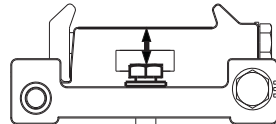

The distance between each wall bracket and the cut line should be 80 mm (3.15'). If the cutting line is exactly vertical or horizontal, and the supporting surface is even, the spirit levels on the wall brackets may be used to line these up exactly at this early stage, after which the expander bolts are tightened to 40 Nm. In other cases it is necessary to wait with tightening the expander bolts until the rail has been mounted on the wall brackets.

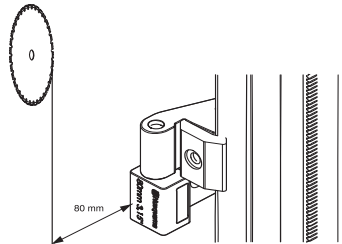

A]ffcfYX`k U`VfUW Yrg

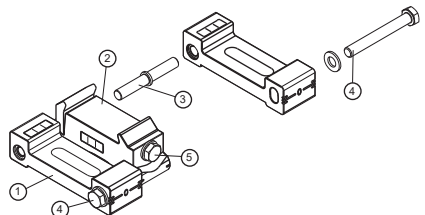

In order to improve access to the locking screws for angle adjustment (4) and/or the locking screw for the clamping washer (5), the wall brackets can be mirrored.

- Remove the screw (4) holding together the two halves of the wall bracket (1) and (2). Separate the two halves.
- Move the pin (3) from one side of the wall bracket half (2) to the other side.
- Press together the two halves again and refit the screw (4) from the other side. In normal position, the index line on the wall bracket half (2) should align with the 0-line on the wall bracket half (1).

7 cbb YW Jcb 'c Zf UJ g

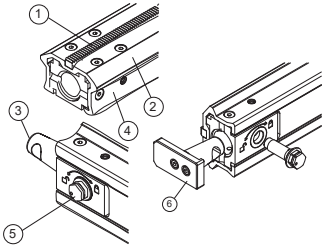

- 1 Gear rack
 - 2 Steering prism for saw carriage guide wheels.
 - 3 Splice connector, rail
 - 4 Clamping surface for wall mounting.
 - 5 Excenter bolt
 - 6 Endstopper, rail
- Mount the splice connector on the end of a rail. Put an ex-center bolt in the hole on the underside of the rail. Make sure that the marking on the bolt is centered over the symbol with the open padlock. The bolt should be pushed in all the way so that the head is flat against the rail. Lock the bolt by turning it clockwise towards the symbol with the locked padlock. Tighten to 40 Nm.

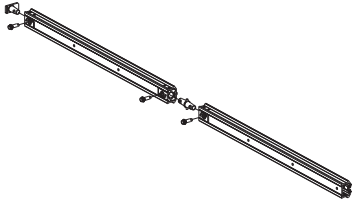

- Mount the other rail on the same splice connector so that both rails meet. Lock it in the same way with another ex-center bolt.

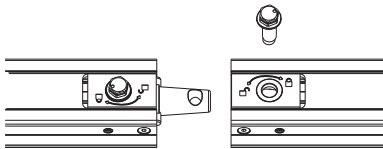

In one end of the completed rail there is a secured end stopper. In the other end a loose end stopper is mounted as in the illustration. The stopper is locked using the ex-center bolt in the same way as the splice connector.

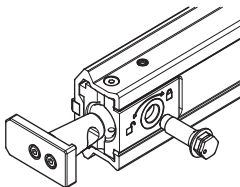

5 ggYa V Y'H Y'f UJ

- Make sure that the expander bolt does not extend beyond the surface of the rail on the wall bracket.
- Snap the rail into both wall brackets. Adjust the rails' position lengthwise, and then tighten the clamping washers on the wall brackets to 40 Nm.

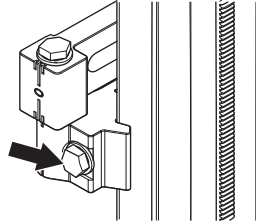

- Make sure that the cutting line is 80 mm (3.15') from the wall bracket. Make sure that the expander bolts are tightened by 40 Nm.

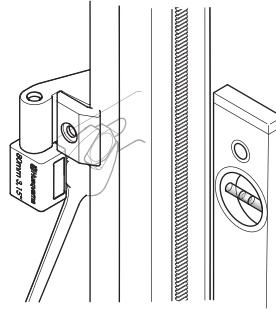

- Adjust the blade angle as needed against the concrete surface by loosening the locking screw for angle adjustment and angling both wall bracket halves in relation to each other.

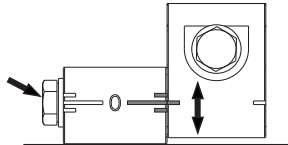

Guk i bjh

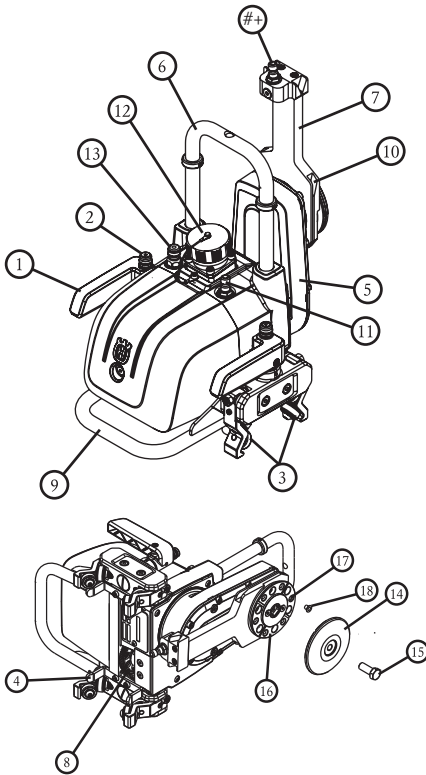

- 1 Locking handle
- 2 Lock button The button on the lock handle must be pressed down in order to free the safety catch in order to open the lock handles.
- 3 Guide wheels Tightened against the rail using the lock handles.
- 4 Controlling.
- 5 Cutting arm The cutting depth is controlled by rotating the arm with the remote control.
- 6 Attachment for blade guard.
- 7 Guide flange for blade guard May be rotated to transport position.
- 8 Feed impeller Runs the saw along the rail.
- 9 Handle
- 10 Guide groove for blade guard
- 11 Outward water connection. Connected to the blade's water connection.
- 12 Electrical connection and control connection
- 13 Water cooling input

- 14 Outer blade flange
- 15 Blade bolt
- 16 Inner blade flange. When cutting flush, the blade is screwed securely into the inner blade flange.
- 17 Screw threads for flush cutting, 6 pcs.
- 18 Plugs for threads, 6 pcs.
- 19 Water connection for blade.

Aci bhk Y'guk 'cbhc 'h Y'fUj''

- Push down the lock buttons on the lock handles and turn the handles out from the sawing unit to free the guide wheels from the sawing bracket on the transport trolley.
- Lift the sawing unit onto the rail with the lock handles opened, and angle the sawing unit over the rail so that the feeding wheel locks into the rack on the rail.
- Then lock the sawing unit to the rail by turning the lock handles back in towards the sawing unit until the lock buttons on the handles pop up and the guide wheels are flush against the rail.

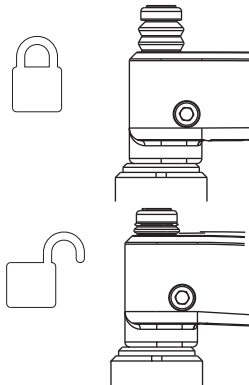

If the sawing unit is mounted on a vertically mounted rail, one should begin by locking the upper lock handle, since when it is locked the saw's weight is relieved and it is easier to lock the lower handle. Make sure at the saw has no play between the guide wheels and the rail, if there is play the guide wheels must be adjusted. See the section 'Adjustment of guide wheels'.



K5 FB-B; 'H: W h k j h ci h h Y'gUk'
gYW fY mUggYa V YX'cb'h Y'fUj''jg
UggcWjUhx'k jh ''Yh U''j'f fml

5 GG9 A 6 @B; '5 B8 '5 8 >I GHA 9 BHG

: jhã Y'V UXY



K5 FB-B; "BY Yf'a ci bhcf'X]ga ci bhã Y' V'UXY'cf'V'UXY'[i UFX'k]ã ci hãzfgñdi "]b[' ci hã Y'dck Yf' V'UX'Y'fi bb]b['tc' hã Y'gUk ' i b]h'7 UfY'Y'ggb'Y'gg'WUb'f'Y'gi 'h]b' gYf'ci g' dYfgcbU']b'1 fmicf'Y'j Yb'XYUA "

It is recommended that Husqvarna diamond blades are used together with the WS 220. Maximum starting blade is 600 mm, and maximum size for blades for deeper cuts is 900 mm. Talk to Husqvarna retailers for recommendations regarding blades for different materials.

- Loosen the blade bolt and remove the outer blade flange.
- Clean the clamping surfaces on the inner and outer blade flange, and check that they are free from grades.

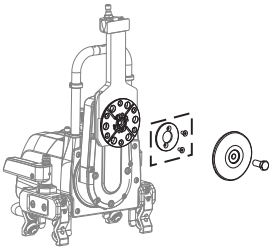

- Also clean and check the clamping surfaces on the blade.
- The inner blade flange has a center spacer for 60 mm factory mounted blade center holes, if blades with 1" center holes are used, the 60 mm spacer may be removed.

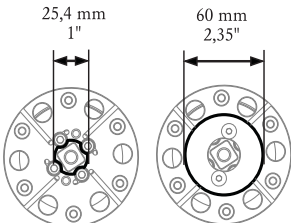

- Check which rotational direction should be chosen with regard to the water spray, for vertical cutting it may be advantageous to direct the water spray down towards the floor.
- Then mount the blade according to the rotation arrow on the blade. If the blade lacks a rotation arrow the diamonds in the segments may be inspected, since the exposed part of the diamonds should lie in the blade's rotational direction.

- Guide the blade up on the center guide and place it against the inner blade flange, hold the blade in place and then mount the outer blade flange with the blade bolt and tighten to 45 nm.
- Check the angle between the blade and the wall using a large set square. If the blade is not perpendicular to the wall, this may now be adjusted on the wall brackets by loosening the locking screw for angle adjustment, and then angling the wall brackets until the blade is in a perpendicular position.

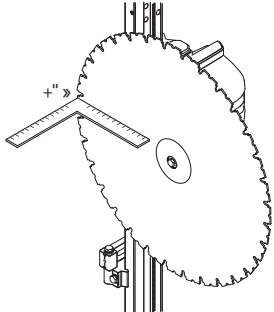

- Adjust the blade angle as needed against the concrete surface by loosening the locking screw for angle adjustment and angling both wall bracket halves in relation to each other.

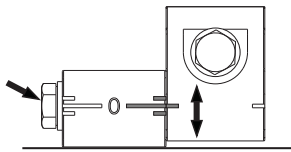

K5 FB-B; "9I YfV]g'Y'V'UX'Y'k \ Yb' UggYa V']b[' hã Y'V'UX'Y'gc' hã U]h]hãXc'Y'g'b'c'h'i f]g' V'Y'W'e'a]b['cc'g'Y'k \ Yb'W' H]b[" 7 UfY'Y'ggb'Y'gg'WUb'f'Y'gi 'h]b' gYf'ci g' dYfgcbU']b'1 fmicf'Y'j Yb'XYUA "

5 GG9 A6 @B; 5 B8 58 >I GHA9 BHG

: JhK YVUXY[i UfX

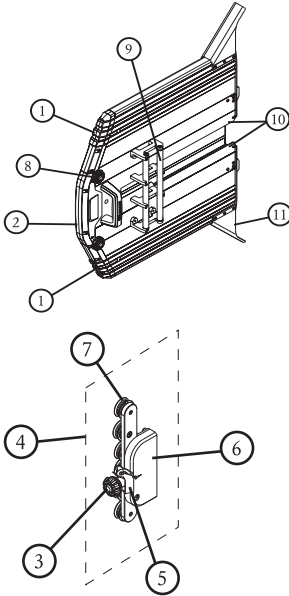

- 1 Outer sections
- 2 Center section
- 3 Locking knob for blade guard
- 4 Blade guard guide
- 5 Blade guard guide lock Blocks the blade guard guide for the blade guard .
- 6 Blade guard attachment. Is mounted on the attachment for the saw unit.
- 7 Guide rollers
- 8 Locking wheels for outer sections
- 9 Guide pipes
- 10 Runners
- 11 Spray guard



K 5 FB-B; °BYj Yf'a ci bhcf X]ga ci bhK Y VUXYcf VUXY[i UfX'k]h ci hZfghdi °]b[ci hK Y dck Yf WUVYfi bb]b['hc' h YgUk i b]h'

The blade guard consists of three sections, a middle section which is mounted on the saw unit as well as two outer sections which are mounted on the middle section. The outer sections are equilateral and may be fitted on either side of the center section.

- Push the blade guard guide between the pipes on the blade guard.

- Make sure that the guide rollers on the blade guard guide roll easily between the pipes.

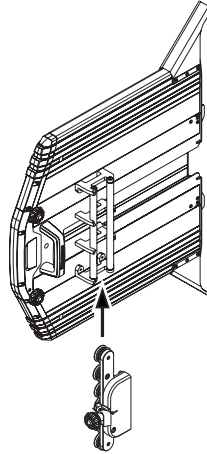

- If the blade guard guide has play between the pipes, the guide rollers must be adjusted. See the section 'Adjustment of blade guard guide'..

: Jh]b['h YVUXY[i UfX'cb'h YgUk 'i b]h

Make sure that the blade guard is undamaged and that the blade guard guide is mounted and centered on the blade guard. In order to facilitate mounting of the blade guard, the outer sections may be removed from the middle section.

- Turn up the guide flange for the blade guard on the saw unit so that the water connection is pointing straight out from the pivot arm.

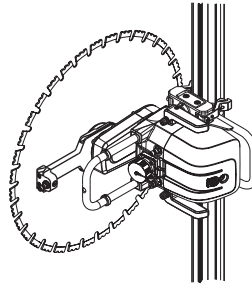

5 GG9 A 6 @B; '5 B8 '5 8 >I GHA 9 BHG

- Aim the blade guard runners on to the guide tracks towards the guide flange and push the blade guard over the blade.

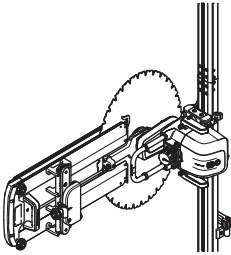

- Fit the blade guard bracket onto the saw unit attachment and screw the locking wheel shut.

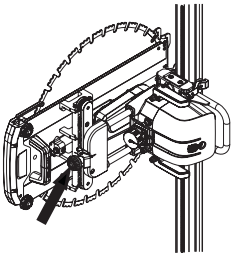

- Make sure that the blade is centered in the blade guard and that the blade is free.

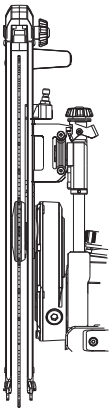

- If the outer sections have been removed during assembly, they may now be mounted by hooking the fork in the lower edge of the middle section and folding the outer section towards the middle section, and then locking with the locking wheels.

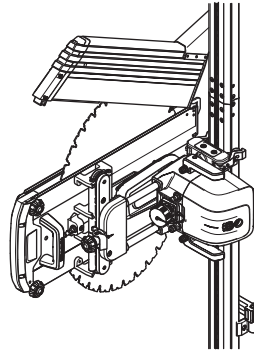

- Connect the water hose between the outgoing water supply connection on the saw body to the water connection on the guide flange.

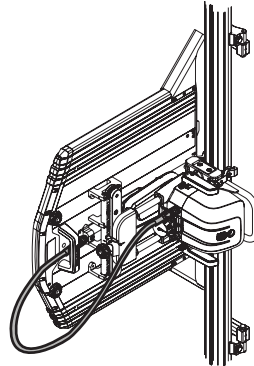

:`i g\`W Hjb[

In order to cut flush against a perpendicular surface, it is possible to attach the blade with six recessed screws directly to the inner blade flange. This must be done before the saw is mounted on the rail, and is best done when the saw is mounted on the transport trolley.

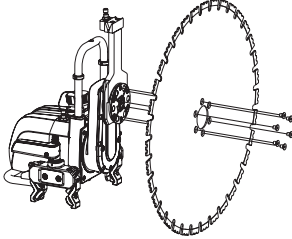

Adjust the wall brackets' distance to the cutting line to approximately 85-90 mm from the cutting line during assembly for flush cutting. A special flush cutting blade guard should be used for flush cutting.

- Remove the blade bolt and the outer blade flange.
- Clean the clamping surface on the inner blade flange and check that it is free from grades.
- Remove the six plugs that protect the screw threads from dirt.
- Center the blade on the guide shoulder and press onto the inner flange.
- Screw on the six included flush cutting screws (MF6S 8x12 10.9 FZB) and tighten crosswise to 30 Nm.
- Assemble the saw with blade on the rail and then adjust the position and angle of the rail after how the blade makes contact to the opposite surface.
- Before cutting is begun, the saw should be fed along the entire length of the planned cut, this in order to check the blade's distance and angle, as well as any uneven parts on the opposing surface.
- Mount the flush cutting guard and make sure that the blade moves freely in the guard.
- Connect the water hose between the outgoing water supply connection on the saw body to the water connection on the guide flange.

7 cbbYWhh Y'dck Yf'dUW

IMPORTANT! This machine is only intended for use together with the Husqvarna PP 220 power unit. All other use is forbidden.

Read through the manual supplied with the power pack before starting to use the machine. Follow the instructions of the chapter 'Menu system' in the PP 220 manual.

- Connect the water hose from the power unit to the inbound water supply connection on the saw unit.

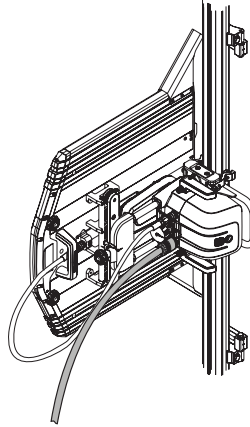

- Connect the power cable between the power unit's upper connection device, which is a power connector for the WS 220, and the saw unit's power connection, then connect the guard lids with each other to prevent dirt from getting into the lids.
- Activate the power unit and start the remote control, make sure that the remote control contacts the power unit via radio communication or through the CAN cable. Follow the instructions in the manual supplied with the power pack.

6 YZ:fY ghUf]b[

- Important Read the section 'Operation' in this manual.
- Read through the manual supplied with the power pack before starting to use the machine.
- Enclose the area to be cut so that unauthorised persons can not be injured or disturb the operator.
- Check that the blade and the blade guard is not damaged or cracked. Replace the blade or the blade guard if it has been exposed to impact or is cracked.
- If cutting is to begin in another position than where the saw unit is located, run the saw unit to the start position.
- Make sure that the sawing system is correctly mounted and that the wall brackets, rails, blade bolt and locking wheels are securely tightened and that there are end stoppers mounted on the ends of the rail.

FYa ch'Wëbfc`

The sawing unit is controlled with the remote control, which is equipped with radio communication for the power unit and may therefore be used without a cable for optimal mobility and supervision during the sawing process.

- Turn off the remote control by pressing the "ON/OFF" button.

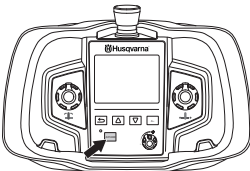

- Longitudinal feed, the dial guides the saw unit's movement along the rail.

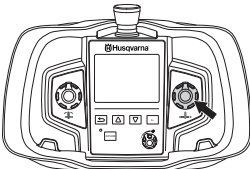

- Arm feeding, the dial guides the pivot arm's movement for changing of the cutting depth.

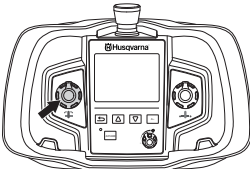

- Rotation of the blade, controls the blade speed. Back arrow button, is used as a double command when starting the blade's rotation. Start the rotation of the blade by holding in the 'back' button while turning the rotation control clockwise. The rotation speed is controlled with a dial.

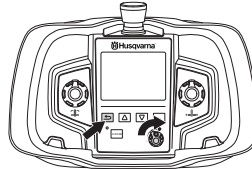

- To switch off the blade rotation, turn the blade rotation control anti-clockwise back to its zero position.

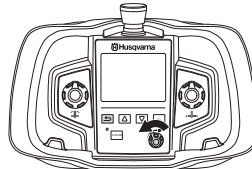

- Stop button

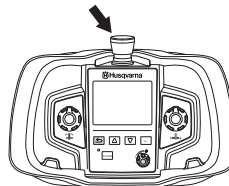

Refer to the manual for the PP 220 for the remote control's other settings and functions.

GHUf]b[

- Activate the power unit by connecting it to a power source and make sure that the RCD and emergency stop are activated.
- Activate the remote control by pressing the "ON/OFF" button.

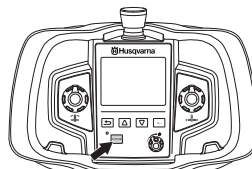

GH FHB; '5 B8 'GHCDD-B;

- Select the required direction of rotation. The direction of rotation can only be altered when the blade is stationary. (DRIVE CHOICES>SET ROT. DIR.)

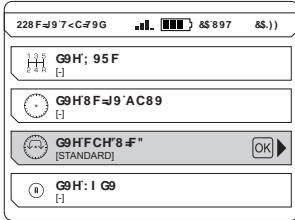

- (a) = Standard (b) = backwards

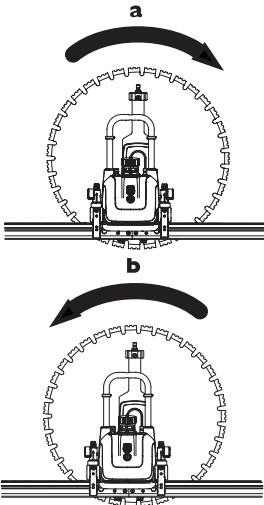

- Become acquainted with the saw unit's longitudinal feed and inward feed by running these functions back and forth a bit, make sure that the blade is not fed into the material and that the saw unit is not run against the end stoppers unnecessarily.
- Run the saw to its starting position and make sure that the blade is not touching the material.
- Start running the water cooling through the system, regulate the flow with the water regulation spigot.
- The blade rotation must be started using the double command. This is done by holding the back arrow button pushed in and simultaneously turning the dial for blade rotation to the desired speed, the double command is there in order to prevent blade rotation from being started accidentally. When the blade rotation has started, the blade engine power output is shown in the display on the remote control.
- Begin by feeding the blade approximately 2-4 cm using the regulator for inward feed.
- Following this, start the longitudinal feed by turning the dial in the desired direction until the power output for the blade engine is at approximately 60-65%, the reason not cutting the guide cut with a higher power output is to ensure that the guide cut is straight. Avoid cutting into rebar when making the guide cut.

- After making the guide cut, subsequent cuts may be made deeper, the depth is determined by material and choice of blade but in normal cases the depth should be between 4-7 cm (1.6'-2.8').
- These cuts should be made at maximum feed speed for optimal use of the saw's capacity. If the power output for the blade engine reaches 100%, the saw automatically regulates the feed speed downwards in order to not overload any connected fuses, in these cases the regulator will keep the power output at 100%. If the power output does not reach 100% during the following cuts, the cutting depth may be cautiously increased.
- If the machine is run on single phase operation, the available output is reduced and the cutting depth must be reduced compared to three phase operation. A rule of thumb might be to reduce the cutting depth by half.
- Often it is more time efficient to cut shallow cuts at higher speed than to cut deep cuts at low speed. Shallower cuts create less cutting surface and thus put higher pressure on the blade segments, which helps to keep the blade sharp and ensures a more efficient cutting.
- When the blade has cut through the material, it is advantageous to feed the blade to the saw's maximum depth, since this reduces the cutting surface and increases pressure on the segments which makes for more efficient cutting. Another benefit of feeding to the maximum depth is that the over cut is shortened.

- (a) = Overcut distance (b) = Cutting surface

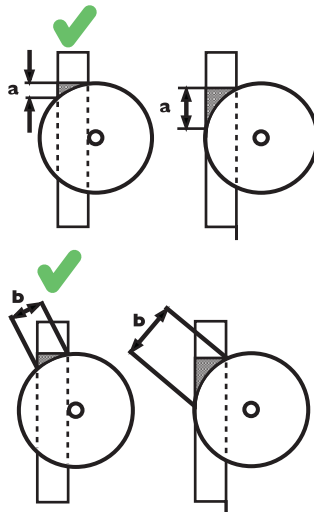

- The blade guard should always be mounted on the saw when in operation. If the blade guard catches the ceiling, for example during over cutting of a doorway, one of the blade guard's gables may be temporarily disassembled.

Grcdd]b[

- After the cutting is finished, the blade is fed out of the wall while rotating until the pivot arm points straight out from the wall.
- Turn off the blade rotation and the water flow.
- Move the saw to a suitable work position for dismantling.
- Turn off the power unit by pressing the emergency stop on the power unit.
- Make sure that the cut blocks are secured with wedges in order to prevent them from falling out during disassembly.
- If further cuts are to be made, the equipment should be moved to the next cut, before moving it the power cable should be released from the saw unit.

8]ga Ubh]b[UbX`WYUb]b[

IMPORTANT! Do not use a high pressure washer to clean the saw.

- When the cutting is completed, the equipment should be cleaned and reassembled on the transport trolley.
- Disconnect the power cable between the saw unit and the power unit, assemble the guards lids on the plug connectors. Hang the power cable on the designated place on the transport trolley.
- Disconnect the water hoses from the saw unit and hang these on the designated place on the transport trolley.
- Clean the equipment using the water hose, a brush and rag. NB! Do not use a high pressure washer or steam cleaning equipment. After cleaning, movable parts should be dried and greased with oil spray in order to prevent corrosion.
- Dismantle the blade guard, clean the blade guard thoroughly inside and out in order to prevent dirt from drying into the guard. Hang the guard on the designated place on the transport trolley. Remove the blade guard guide and place it in the designated accessory box.
- Dismantle the blade, hang it on the designated place on the transport trolley and secure it using the outer blade flange and the blade bolt.
- Release the saw unit from the rail by pressing down the locking buttons and folding out the locking handles. Carry the saw unit to the designated place on the transport trolley and secure it with the locking handles.
- Dismantle the rail by releasing the clamping washer carriage bolts on the wall brackets and lifting the rail out of the brackets. Then separate the rails by releasing one of the ex-center bolts in the middle of the rail, place both of the rail units on the designated place on the transport trolley with the end stoppers facing down. Dismantle the wall brackets and place these in the designated accessory box.

Gyf j JW

IMPORTANT! All types of repairs may only be carried out by authorised repairmen. This is so that the operators are not exposed to great risks.

After 100 hours of operation, the message "Time for servicing" is displayed. The entire equipment shall then be taken to an authorized Husqvarna dealer for servicing.

A UjbHybUbw

IMPORTANT! Inspection and/or maintenance should be carried out with the motor switched off and the plug disconnected.

8 Uj ma UjbHybUbw

- 1 Check that all couplings, connections and cables are intact and free from dirt. Use a brush or a cloth and wipe clean, lubricate the contact pins with a lubricating and cleaning spray. Also lubricate the water couplings' sleeves.

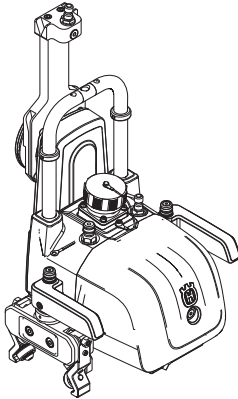

- 2 Clean and lubricate the moving parts and springs of the machine, such as the handle's locking function and the blade guard guide spring mechanism. Spray with a cleaning and lubricating spray.
- 3 Make sure the blade and blade guard are not damaged and cracked or damaged in any other way. Replace the blade guard and/or blade if they have been exposed to abnormal wear. Also check that the blade guard guide wheel turns without too much resistance, and that the guide is correctly aligned with the blade guard and the saw. See the assembly and settings when adjusting sections.
- 4 Check that the hoses and cables are intact.
- 5 Clean the outside of the machine. Do not use a high pressure washer to clean the saw.

5 X1 ghjb['h Y[i]XY'k \ YYg

In order for the saw to run stably and saw a straight cut, the four guide wheels must rest against the rail and not have too much play.

The guide wheels should be adjusted on the side shown in the figure, the opposite side is a fixed position that should only be adjusted during maintenance at an authorized Husqvarna service workshop.

If the saw has too much play, the guide wheels must be adjusted as follows:

- Use a 13 mm spanner to loosen the nut (A).
- Screw in the stop screw (B) with a 4 mm Allen key until the guide wheels are on the rails and there is no more play.
- Hold the stop screw (B) in this position with the Allen key while tightening the nut (A) to lock the stop screw.

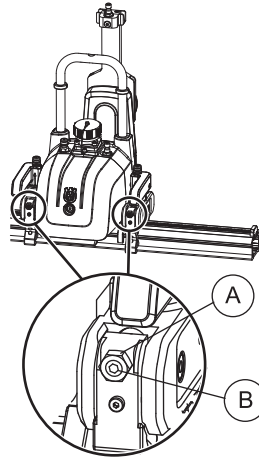

5 X1 ghjb['h YVUXY[i UFX[i]XY

In order for the guide rollers on the blade guard to run evenly without play, the guide rollers on the blade guard guide must be adjusted correctly. If the blade does not center in the blade guard and if there is play on the guide rollers between the blade guard pipes, they must be adjusted as follows.

- Insert the blade guard guide between the pipes on the blade guard.
- Loosen the two hex screws slightly with a 5 mm Allen key but do not unscrew them completely

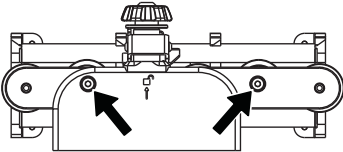

- Then turn the two eccentric shafts loosened by the hex screws with a 22 mm spanner until they are against the upper pipe on the blade guard.

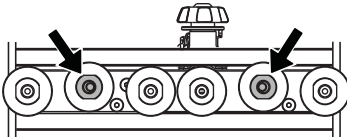

- Then hold the eccentric shafts with the 22 mm spanner while tightening the hex screw to lock the shaft.

H97 < B75 @85H5

K G &&\$

K G &&\$

K Y[\ h

Saw unit, kg	19
Blade guard 600 mm, kg	9,5
Blade guard 900 mm, kg	14,0
Rail total weight, kg	11,0

6`UXY gInY

Blade size - max, mm/inches	900/36
Blade size - min, mm/inches	500/10
Starting blade - max, mm/inches	600/19
Cutting depth blade 600 - max, mm/inch	245/9,6
Cutting depth blade 900 - max, mm/inch	395/15.5
Motor for saw blade drive	PM High cycle
Spindle output - max, kW	6
Power train	Gear drive
Output speed, rpm	0-1150
Feedingsystem/control	Electric/auto
Drive torque at saw blade - max, Nm	68
Cooling water temp. in at 3,5 l/min - max, C	35
Cooling water pressure - max, bar	7

Bc]gY Ya]gg]cbg'fgYY'bcH'&L

Sound power level, measured dB (A)	104
Sound power level, guaranteed L _{WA} dB (A)	105

Gci bX`Yj Y g'fgYY'bcH'&L

Sound pressure level at the operators ear, dB(A)	83
--	----

Note 1: Noise emissions in the environment measured as sound power (L_{WA}) in conformity with EN 15027/A1.

Note 2: Noise pressure level according to EN 15027/A1. Reported data for noise pressure level has a typical statistical dispersion (standard deviation) of 1.0 dB(A).

F YWt a a YbXYX V UXY'gdYYX



K 5 FB-B; *7 i H]b[`Uhtc` \][\ `fYj g`VUb`VUi g`YXLa U[Y`tc`h`Y`V`UXY`UbX`YUX`tc`dYfgcbU`]b4 fml

	*\$\$'a a`fB(ÎL	+\$ \$'a a`fB, ÎL	, \$\$'a a`fî &L	- \$\$'a a`fî) ÎL
*\$\$'fda				
+\$ \$'fda				
, \$\$'fda				
- \$\$'fda				
%\$\$ \$'fda				
%&\$\$ \$'fda				
%& \$'fda				

7 cbWYHr	
	Hard
	Medium
	Soft

For recommended blade speed, please contact blade retailers.

H97 < B=75 @85H5

8 ja Ybgjcbg

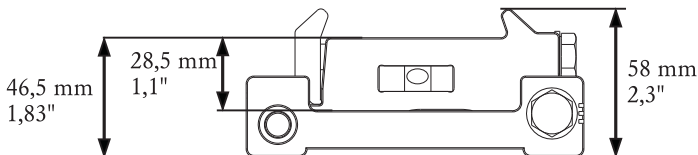
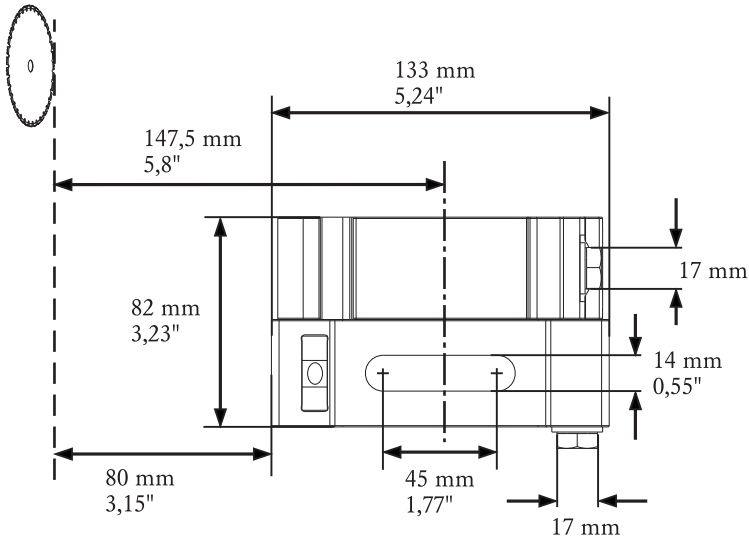
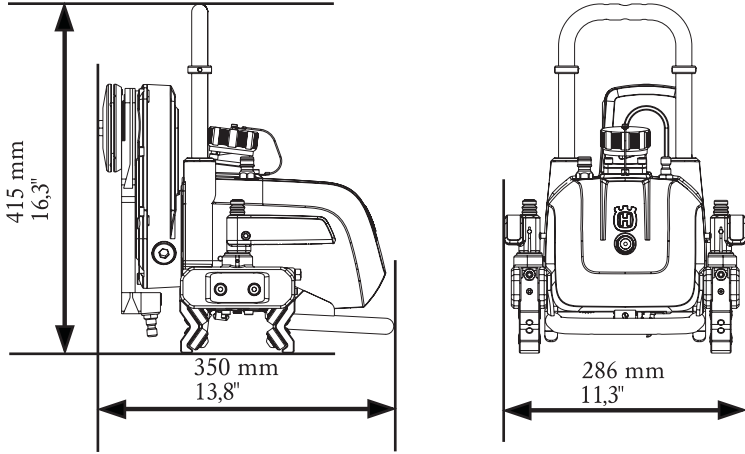

97 '8 YWUfUjcb'cZ7 cbZfa Jlm

(Applies to Europe only)

<i ge j UrbU5 6 , Huskvarna, Sweden, tel.: +46-31-949000, declares under sole responsibility that the wall saw <i ge j UrbUK G &&& <: dating from 2013 serial numbers and onward (the year is clearly stated on the type plate, followed by the serial number), complies with the requirements of the COUNCIL'S DIRECTIVE:

- of May 17, 2006 "relating to machinery" &&&* # .
- of December 15, 2004 "relating to electromagnetic compatibility" &&&(#/%, #07 .
- of December 12, 2006 "relating to electrical equipment" &&&* #) #07 .
- of June 08, 2011 on the 'restriction of use of certain hazardous substances' &&%0/#) #01

The following standards have been applied: EN ISO 12100:2010, EN 55014-1:2006, EN 55014-2/A1:2001, EN 61000-3-11:2000, EN 15027/A1:2009.

Gothenburg 3 February 2015



Helena Grubb

Vice President, Construction Equipment Husqvarna AB

(Authorized representative for Husqvarna AB and responsible for technical documentation.)

TECHNICAL DATA

UK Declaration of Conformity

We, Husqvarna AB, SE-561 82 Huskvarna, SWEDEN, Tel: +46 36 146500 declare on our sole responsibility that the product:

Description	Wall Saw
Brand	Husqvarna
Type/Model	WS 220
Identification	Serial numbers dating from 2021 and onwards

complies fully with the following UK directives and regulations:

Regulation	Description
S.I. 2008/1597	The Supply of Machinery (Safety) Regulations 2008
S.I. 2016/1091	Electromagnetic Compatibility Regulations 2016
S.I. 2016/1101	The Electrical Equipment (Safety) Regulations 2016
S.I. 2012/3032	The Restriction of the Use of Certain Hazardous Substances in Electrical and Electronic Equipment Regulations 2012

and that the following harmonized standards and/or technical specifications are applied;

EN ISO 12100:2010

EN 55014-1:2006+A1:2009+A2:2011

EN 55014-2:2015

EN 61000-3-11:2000

EN 15027/A1:2009

EN IEC 63000:2018

UK Importer:
Husqvarna UK Limited
Preston Road, Aycliffe
Business Park Newton
Aycliffe, County Durham
UK DL5 6UP

Partille, 2022-06-10



Erik Silfverberg

R&D Director, Concrete Sawing & Drilling Equipment

Husqvarna AB, Construction Division

Responsible for technical documentation

**UK
CA**